

Title		
X1M Pro Base Board B2B		
Size	Number	Revision
A4		
Date:	13-Sep-2013	Sheet of
File:	E:\产品设计文档\电台产品设计文档\X1M Pro\X1M Pro.ddb	

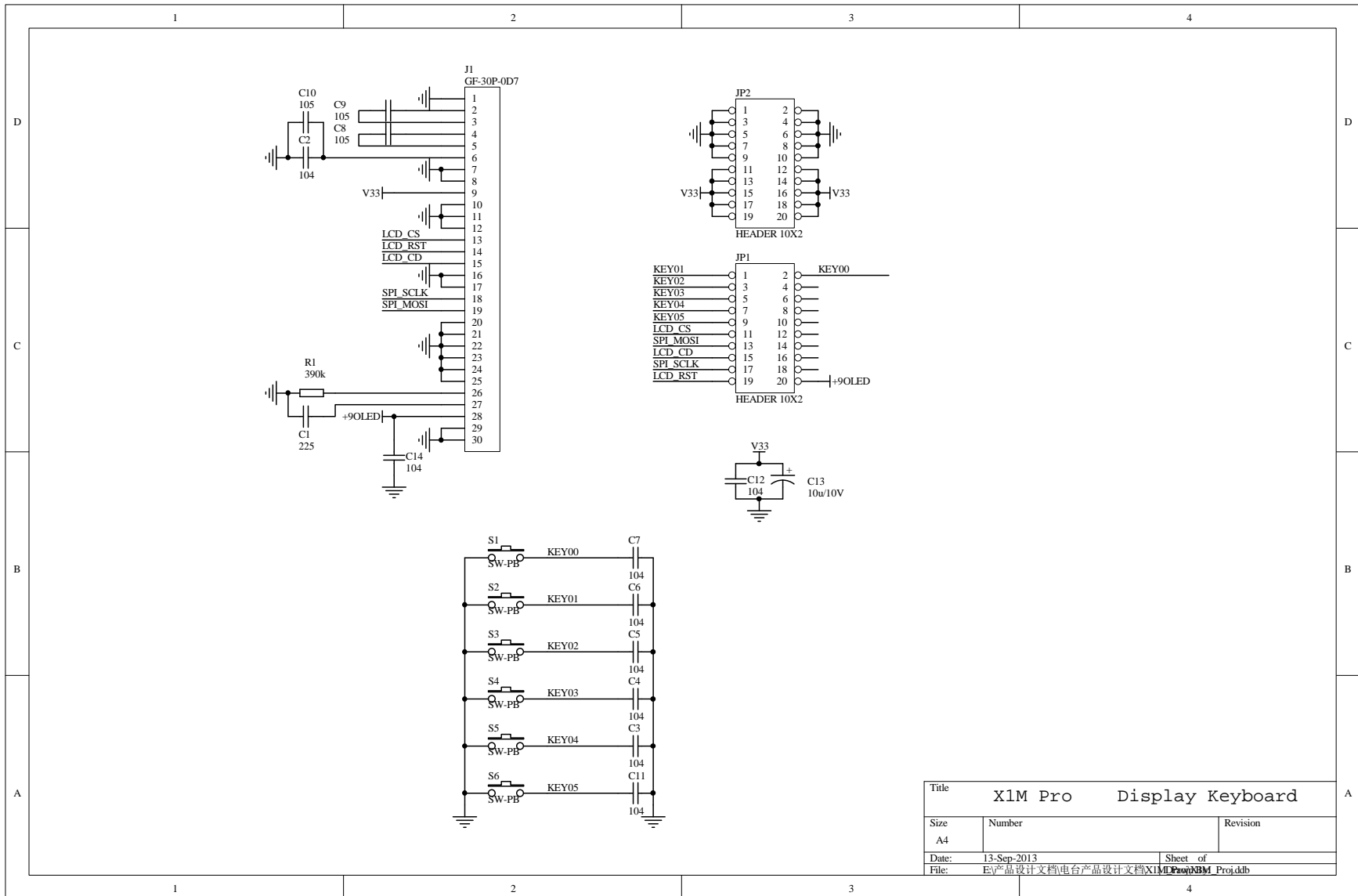

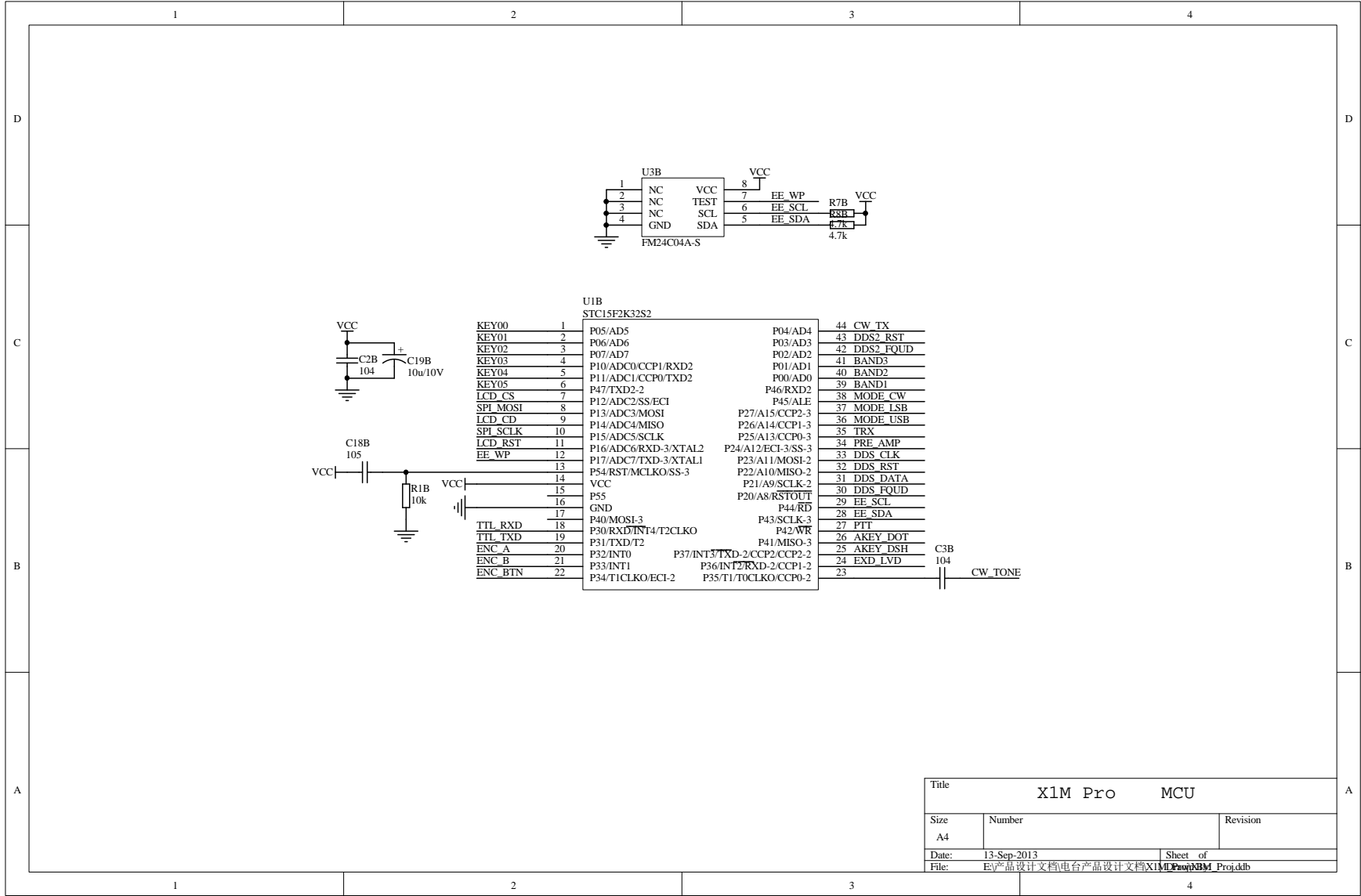

Title			X1M Pro MCU		
Size	Number	Revision			
A4					
Date:	13-Sep-2013	Sheet of			
File:	E:\产品设计文档\电台产品设计文档\X1M Pro\X1M Pro1.dtb				

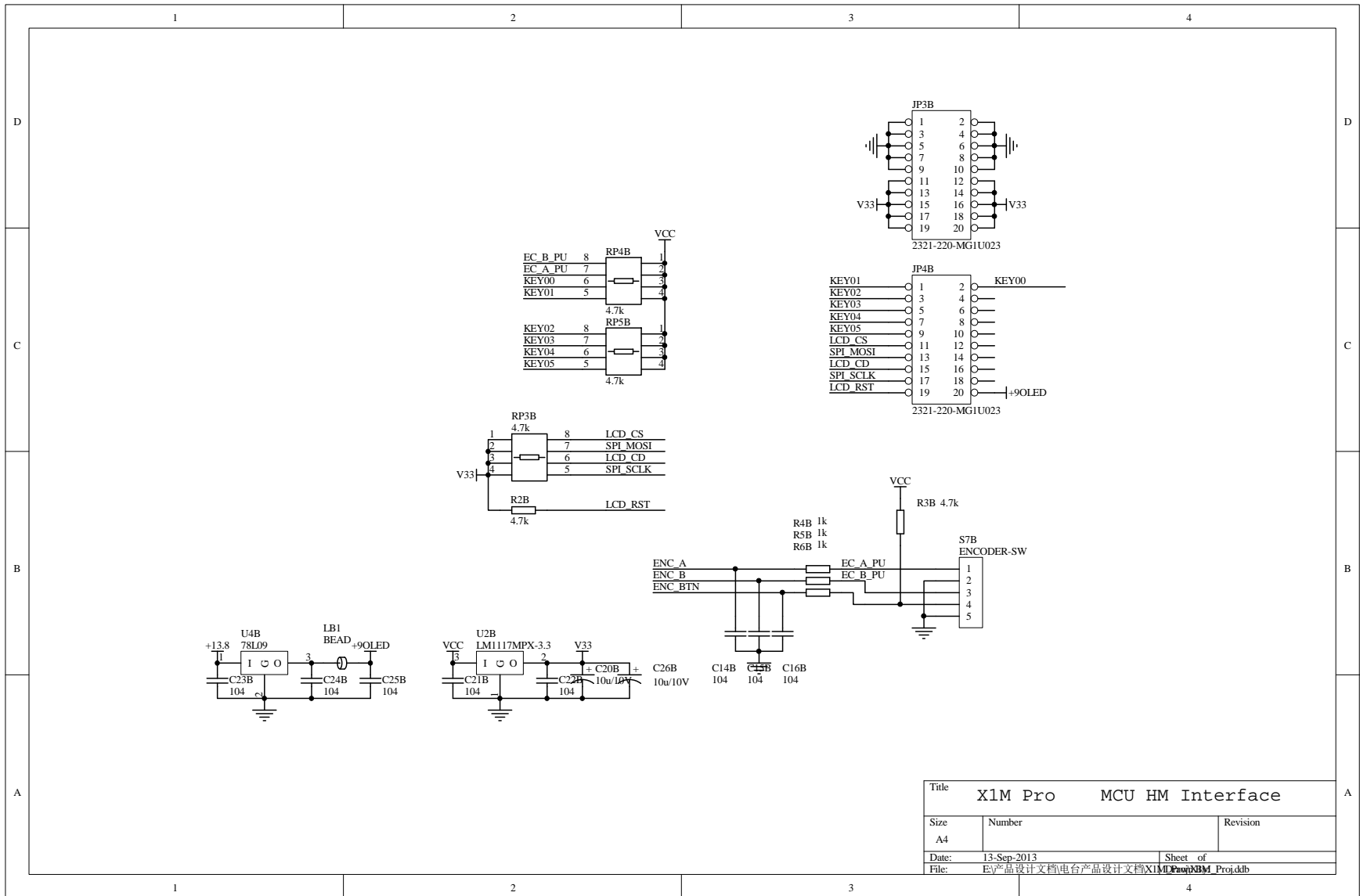

Title		
X1M Pro MCU HM Interface		
Size	Number	Revision
A4		
Date:	13-Sep-2013	Sheet of
File:	E:\产品设计文档\电台产品设计文档\X1M Pro\X1M Pro.ddb	

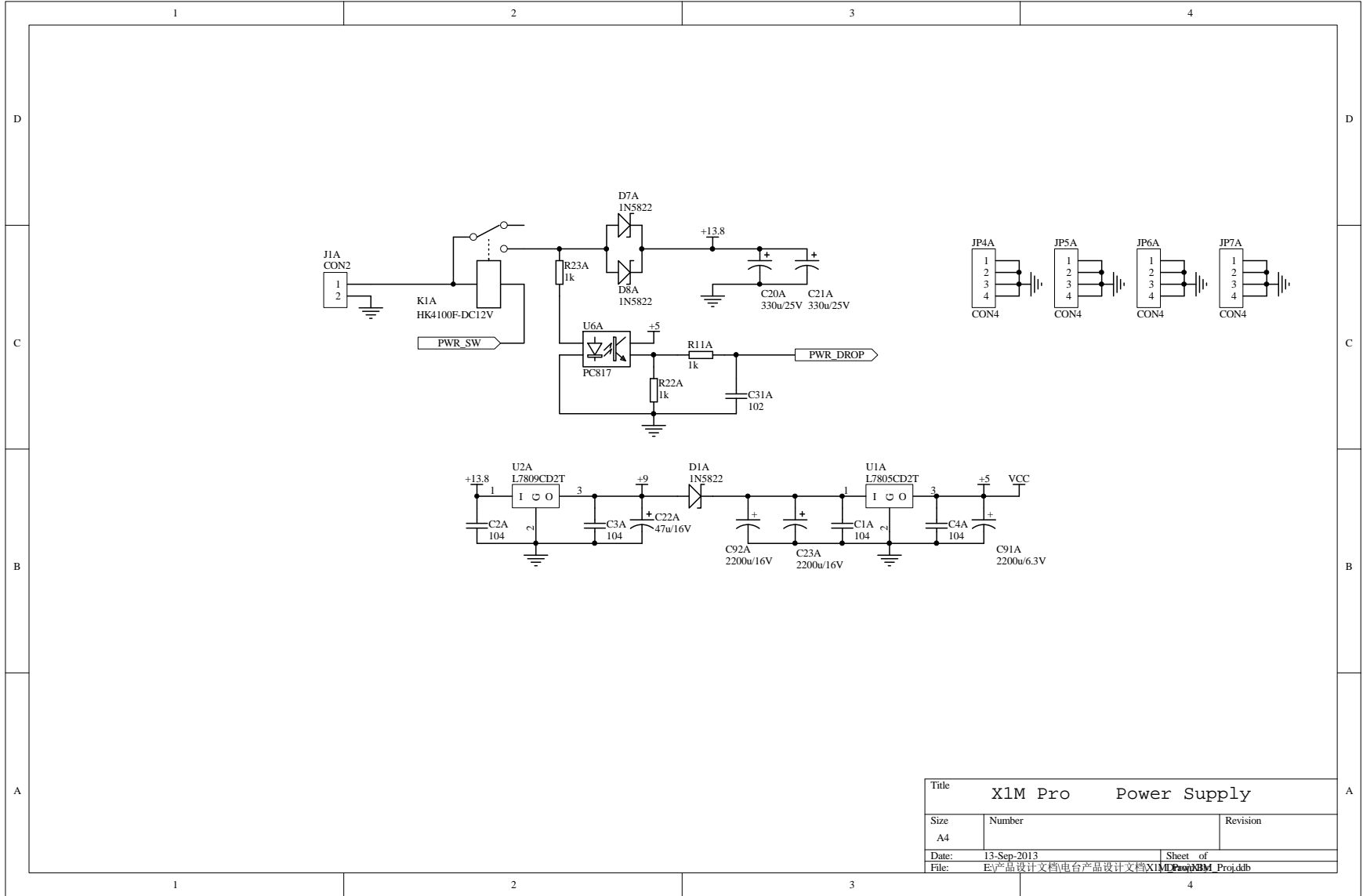

Title		
X1M Pro Power Supply		
Size	Number	Revision
A4		
Date:	13-Sep-2013	Sheet of
File:	E:\产品设计文档\电台产品设计文档\X1M Pro\X1M Proj.ddb	

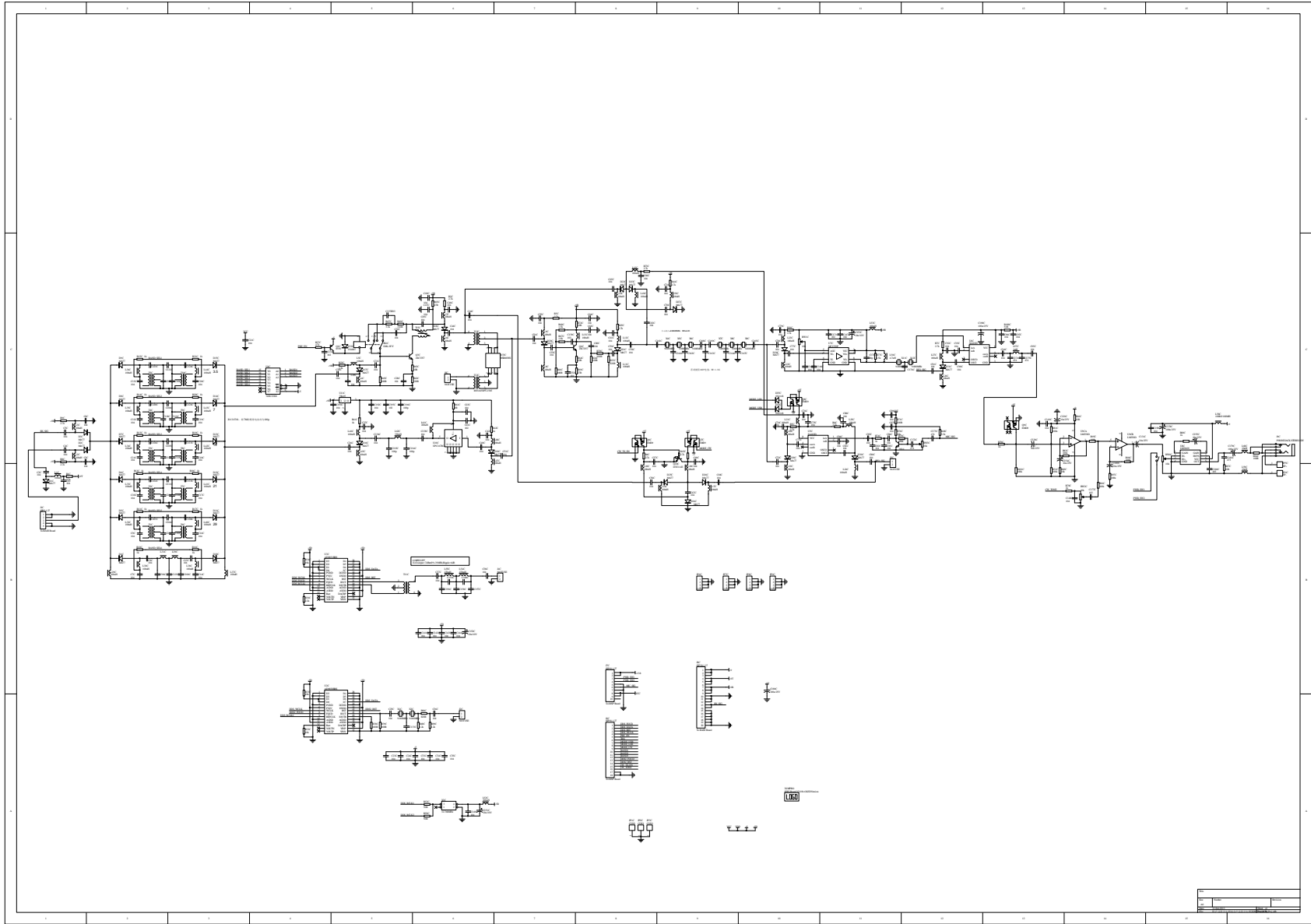

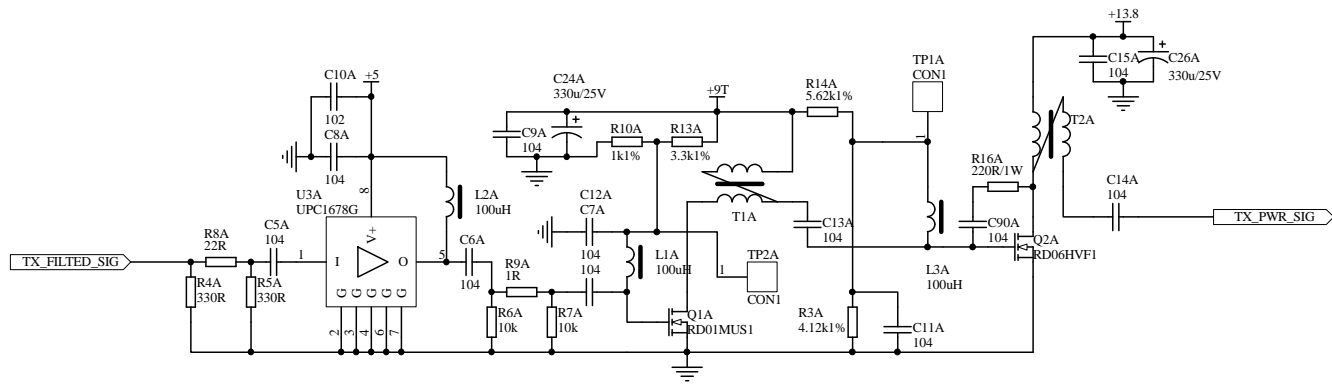

Title		
X1M Pro TX Power Amp		
Size	Number	Revision
A4		
Date:	13-Sep-2013	Sheet of
File:	E:\产品设计文档\电台产品设计文档\X1M Pro\X1M Pro.sch	

BAND	BPF	LPF
3.5-3.9M	B0	L1
7.0-7.15M	B1	L2
14.0-14.4M	B2	L3
21.0-21.45M	B3	L4
28.0-29.7M	B4	L5
0-30M	B5	

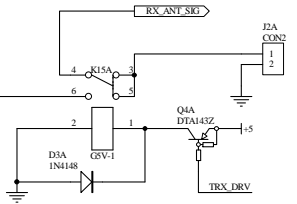
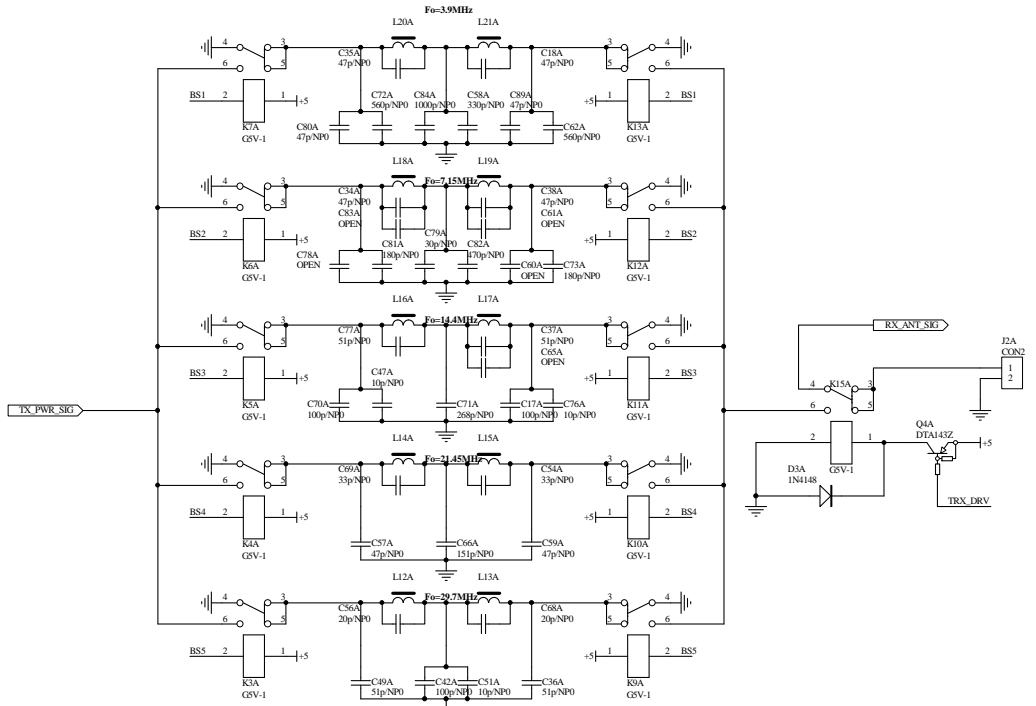
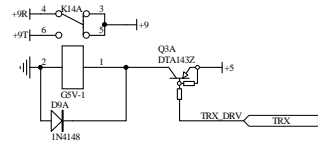
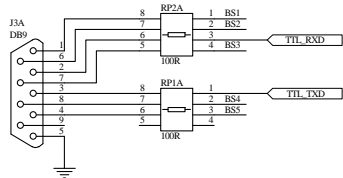
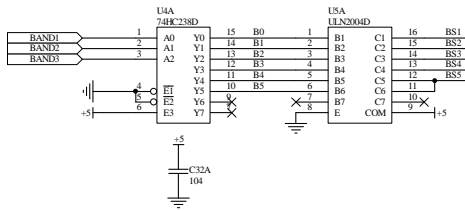

Title X1M Pro TX Filter		
Size A3	Number	Revision
Date 13-Sep-2013	Sheet of	
File E:\产品\设计文档\电台产品\设计文档\X1M Pro\X1M Pro.dtb		